

# HydroFloTech: Coatings Standards

## Typical Coating Specifications

- Interior surfaces are to be blasted to a SSPC SP-10 near white metal blast.
- Exterior surfaces are to be blasted to a SSPC-SP-6 commercial blast.
- All threads and gaskets are to be masked before blasting and coating application.
- Remove all masking materials prior to shipment.
- All coatings are to be applied in strict accordance with manufacturer's specifications.

## Interior Paint Standard

- Brand: International - No Substitute
- Name: Interseal 670 HS, 1-2 Coats (10-12 Mil Total DFT)
- Activator: Low Temperature Activator

## Exterior Paint Standard

- Brand: DuPont - No Substitute
- Primer: Corlar 2.1 ST White Epoxy Mastic (3 Mil DFT Minimum)
- Top Coat: Imron 2.8 HG High Gloss Polyurethane (1-1/2 Mil DFT Minimum)
- Color: Safety Blue.

## AVAILABLE OPTIONS (SOME NOT SHOWN):

- \*COVERS (STANDARD OR VAPOR TIGHT)
- \*1/6 HP, 460V PADDLE STYLE SLUDGE THICKENER
- \*TRANSFER PUMP PACKAGE(S)
- INFLUENT
- OIL
- EFFLUENT
- SLUDGE
- \* LEVEL SWITCHES
- \*CONTROL PANEL
- \* ALSO AVAILABLE IN 304SS AND 316SS

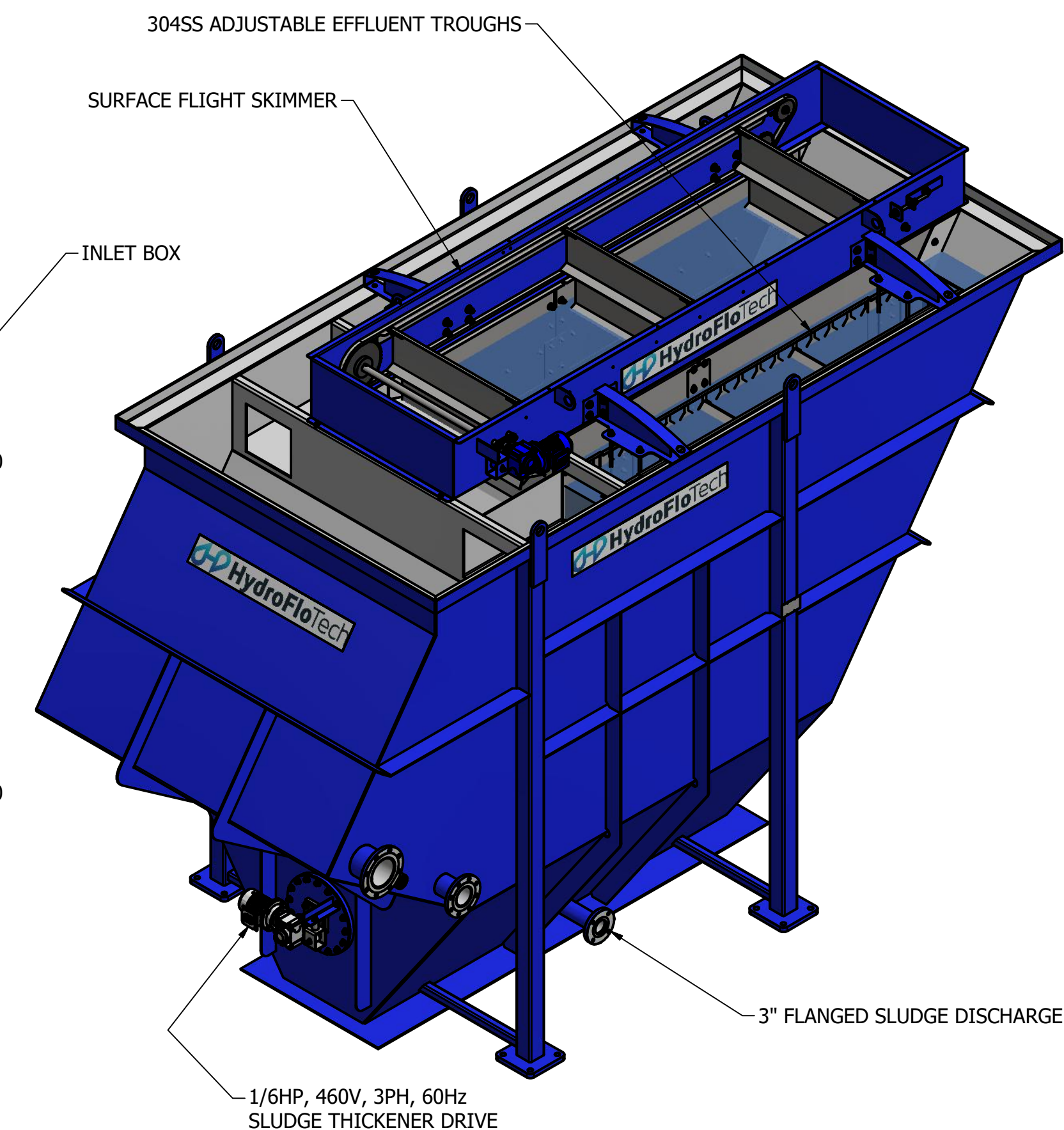
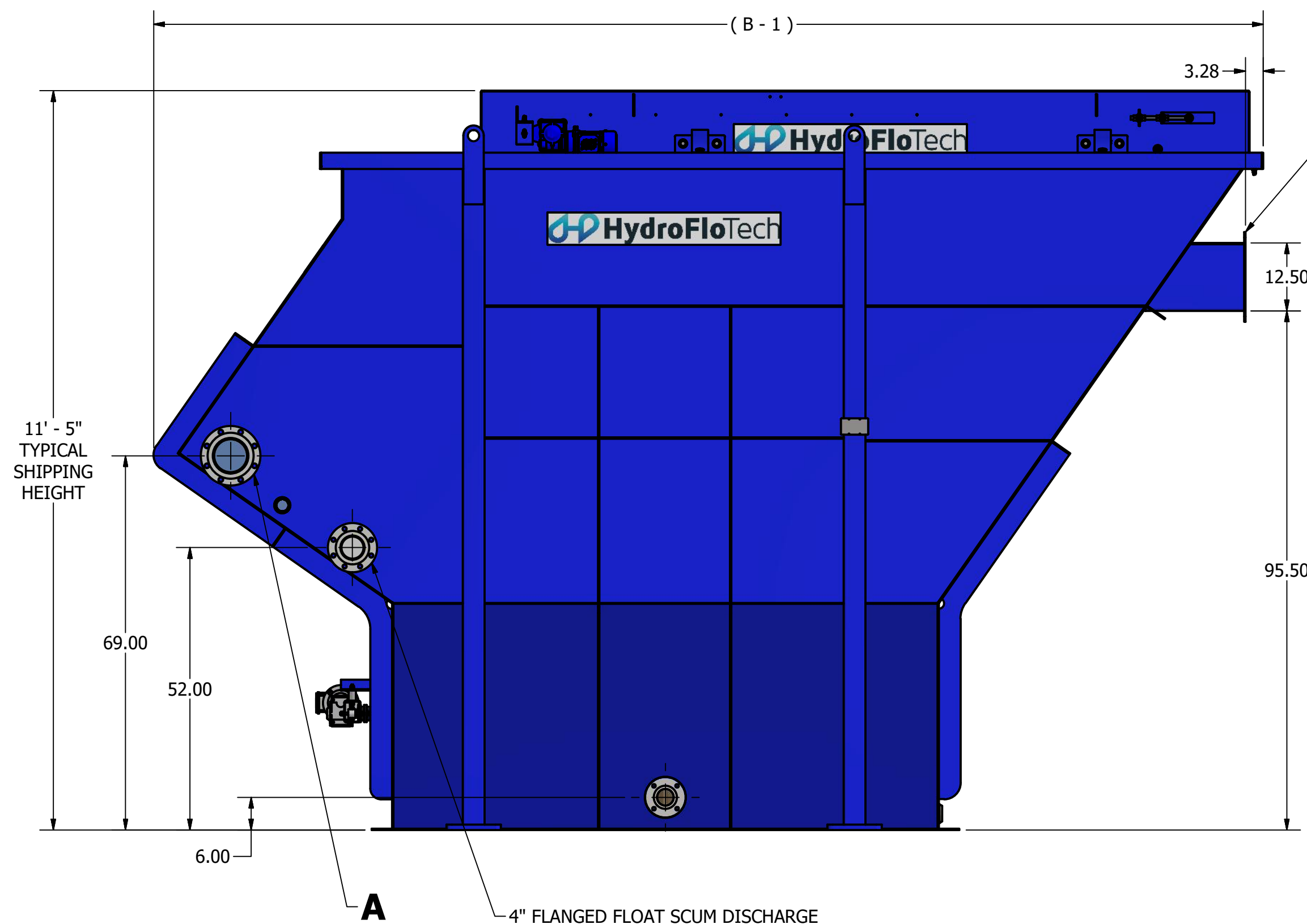
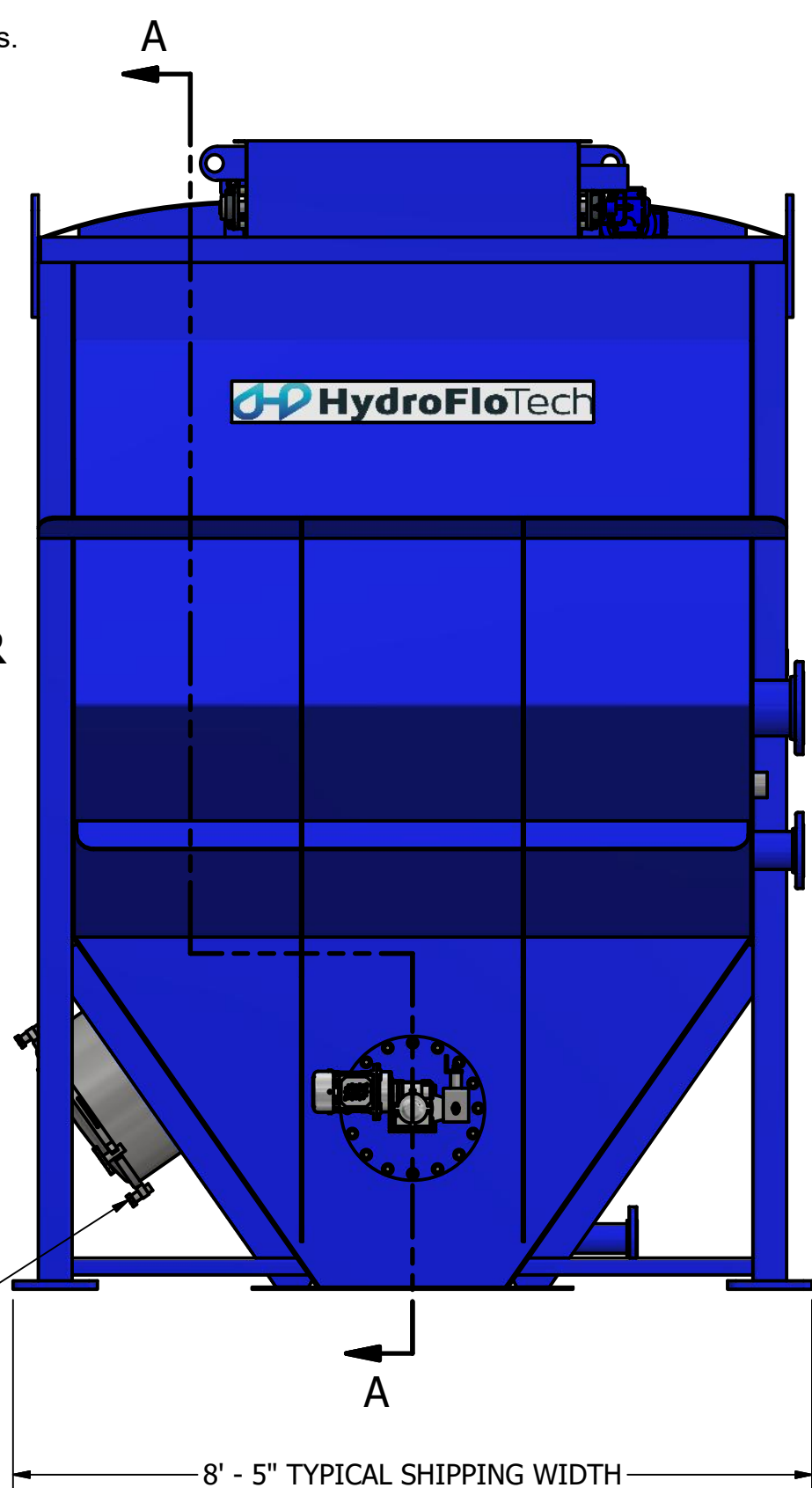

MODEL#	EFFECTIVE PSA @ 2" ( SQ. FEET )	EFFLUENT FITTING ( A )	UNIT LENGTH ( B - 1 )	SLUDGE CHAMBER ( GALLONS )	TOTAL CAPACITY ( GALLONS )	SHIPPING WEIGHT ( POUNDS )	OPERATING WEIGHT ( POUNDS )
CLD-090	307	4"	12' - 11"	455	2,654	6,591	27,886
CLD-135	461	6"	15' - 0"	681	3,497	7,826	35,731
CLD-180	615	6"	17' - 0"	907	4,340	9,101	43,617
CLD-225	769	6"	19' - 1"	1,133	5,183	10,435	51,562
CLD-270	922	8"	21' - 1"	1,359	6,026	12,001	59,738
CLD-315	1,076	8"	23' - 2"	1,585	6,868	13,328	67,668
CLD-360	1,230	8"	25' - 2"	1,811	7,712	14,662	75,621
CLD-405	1,384	8"	27' - 3"	2,037	8,555	16,235	83,804
CLD-450	1,538	10"	29' - 3"	2,263	9,396	17,687	91,850
CLD-495	1,692	10"	31' - 4"	2,489	10,242	19,014	99,813
CLD-540	1,845	10"	33' - 4"	2,715	11,084	20,528	107,929
CLD-585	1,999	10"	35' - 5"	2,941	11,927	21,855	115,867
CLD-630	2,153	10"	37' - 5"	3,167	12,770	23,189	123,811
CLD-675	2,307	10"	39' - 6"	3,393	13,613	24,762	131,995
CLD-720	2,461	12"	41' - 6"	3,619	14,456	26,096	139,940
CLD-765	2,615	12"	43' - 7"	3,845	15,299	27,423	147,877
CLD-810	2,768	12"	45' - 7"	4,071	16,142	28,996	156,061
CLD-855	2,922	12"	47' - 8"	4,297	16,985	30,324	163,999
CLD-900	3,076	12"	49' - 8"	4,523	17,828	31,658	171,944
CLD-945	3,230	12"	51' - 9"	4,749	18,671	33,231	180,128
CLD-990	3,384	12"	53' - 9"	4,975	19,514	34,558	188,065

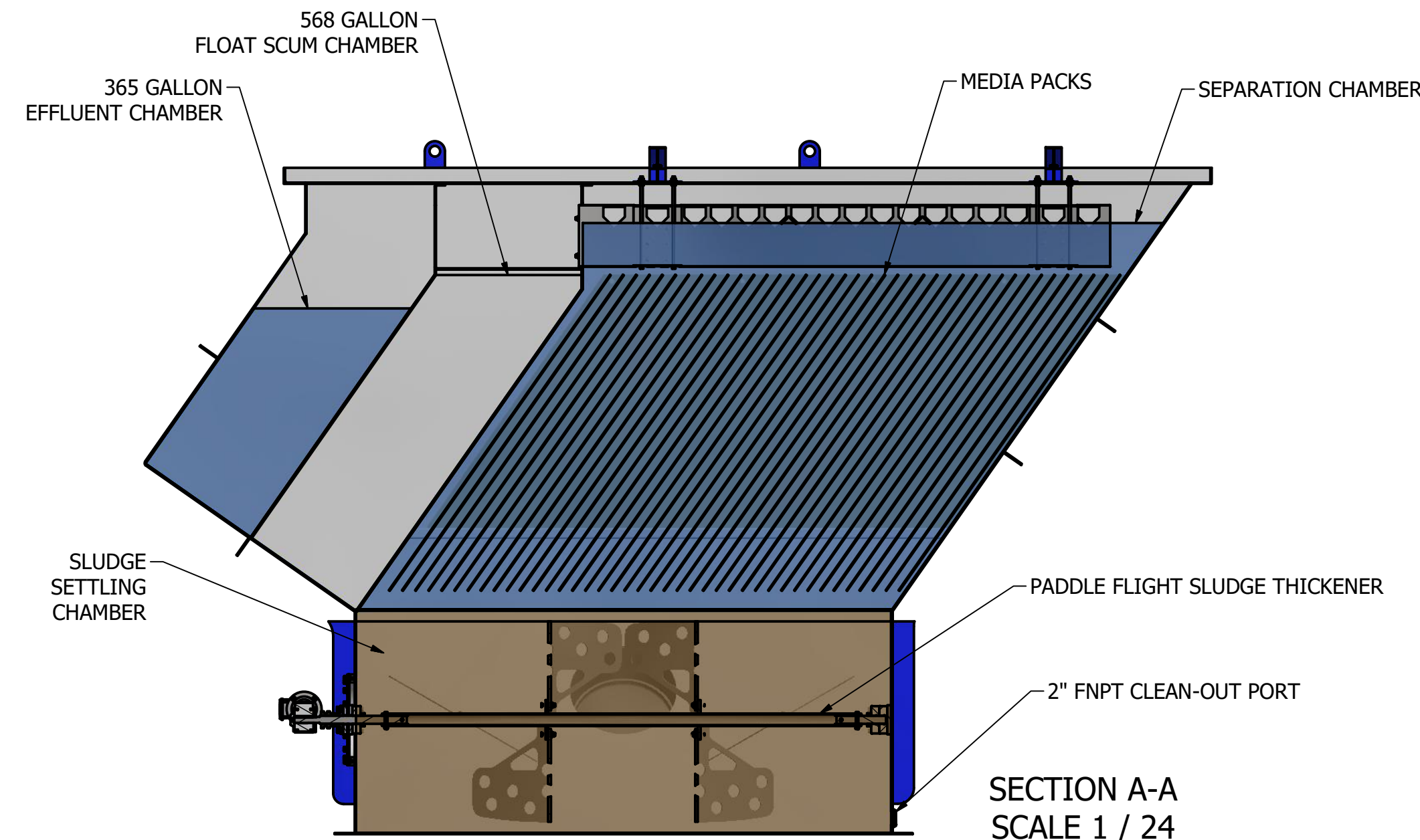

**HydroFloTech**  
 1875 BIG TIMBER ROAD  
 ELGIN, IL 60123  
 (630) 762-0380  
 www.hydroflotech.com

DRAWN T. SUMMERS	5/22/2020	ISSUED FOR INFORMATION ONLY	
CHECKED		TITLE	
QA		HydroFloTech, INCLINED PLATE CLARIFIER, CLARIDAF, CLD-XXX, CARBON STEEL	
MFG		SIZE	DWG NO
APPROVED		D	CLD-TABULATED
		SCALE	REV
		1 / 20	0
		SHEET 1 OF 1	